

## Research article

# Testing the Performance of a Water Restrictor With the Orifice Principle

Elsa Try Julita Sembiring<sup>1\*</sup>, Pratama Haditua Reyner Siregar<sup>2</sup>, and Nilam Atsirina Khrisnaputri<sup>1</sup>

<sup>1</sup>Universitas Agung Podomoro, Jl. Letjen S. Parman No.28 Grogol Petamburan, West Jakarta, Indonesia

<sup>2</sup>Universitas Trisakti, Jl. Kyai Tapa No.1, Grogol Petamburan, West Jakarta, Indonesia

## Abstract.

The habit of wasting water is widespread. One of the solutions is to “force” the consumer to conserve water by restricting the flow using a restrictor with the orifice principle. The aim of this study was to determine the performance of a restrictor in a pipeline model by defining the discharge coefficient obtained experimentally from the output discharge with or without the restrictor in static pressure water, and to examine the variation based on the tap opening. The restrictor had an opening at the center of the cylinder with a 2.5 mm diameter and it was installed in a water tap of 0.5 inches diameter based on the market. The effectiveness of the tool in reducing the water was determined by the discharge coefficient. Based on the results, it was found that the restrictor was capable of reducing the water discharge output by 60%-70% for discharge inputs ranging from 0.15 to 0.25 l/s. Moreover, the reduction for discharge inputs below 0.15 l/s resulted in an efficiency ranging from 30%-40%. The discharge output using the restrictor was approximately 0.06 to 0.07 l/s. The contraction coefficient and expansion coefficient were 1.720 (experimental) and 1.484 (theoretical).

**Keywords:** water wasting reduction, water restrictor, orifice principle, experimental approach

## 1. Introduction

Water scarcity is a situation when there is a water shortage to meet need. Factors of water scarcity: 1) increased demand, 2) uneven distribution of fresh water, and 3) increased water pollution [1]. Various efforts for water conservation could be done by applied water-saving behavior and technological approach. Technology approach could replace the conventional tool that saved water better. Various studies have shown that the water-saving tools could save water consumption of more than 34% or equivalent to 171 liters of water per person per day. This mean saving approximately 34,000 liters of water per person per year [2]. This technology was generally installed on taps, showers, toilets and washing machines.

Corresponding Author: Elsa Try Julita Sembiring; email: elsa.try@podomorouniversity.ac.id

Published: 12 October 2022

Publishing services provided by Knowledge E

© Elsa Try Julita Sembiring. This article is distributed under the terms of the [Creative Commons Attribution License](#), which permits unrestricted use and redistribution provided that the original author and source are credited.

Selection and Peer-review under the responsibility of the ICGE 2021 Conference Committee.

 OPEN ACCESS

Main problem in changing wasteful behavior is the public ignorance about the importance of water saving. To “force” restricting the water flow was one of way to support the water-saving habits by using technology approach. However, it had to be fit to various type of tap in the market. Moreover, the price of the tool had to be affordable and easily installed but not too easy to take it off. The performance of the tool needs to be known to anticipate various water pressures at the consumer home.

The purpose of this research is to determine the performance of water restrictor at various discharge with the following details:

1. Pressure loss on the circuit without and with restrictor
2. Effect of the restrictor on discharge efficiency
3. Determination of the contraction and expansion coefficient of the restrictor (K) theoretically and experimentally

A restrictor is a tool with an orifice principle designed to limit water flow coming out of a tap or other dispenser. The water valve tap opening greatly determined the water would come out of the tap.

There are several reasons to install the orifice in a piping system:

1. Increase flow pressure
2. Reducing the discharge in the same direction
3. Increase the velocity of the fluid in the same direction

## 2. 2. Method

The testing of the water restrictor performance consisted of three major steps:

### 2.1. Preparation of Piping Circuit

The circuit consists of PVC pipes with a diameter of ½” that branched into two pipe (without and with a restrictor) ending with a water tap. The restrictor was inserted before the pressure gauge. The restrictor and the circuit used were shown in Figure 1.



(a) Restrictor



(b) Piping circuit

Figure 1: Restrictor and Piping Circuit.

## 2.2. Measurement of Water Discharge in the Tap without and with a Restrictor

Restrictor with opening diameter 2.5 mm was inserted before the tap. Then, the circuit was connected to pressurized water line. In this research, hydraulic bench was used to ensure that the water was circulated during the experiment. First, both taps were shut, while the ball valve that was installed at the beginning of the circuit was fully open. Next, the static pressure of the circuit was measured by pressured gauge.

Measurement of water volume and time at the tap without restrictor by fully opening the tap and holding the water in a container. When the tap was opened, stopwatch started to count until 15 seconds. When the stopwatch was off, the time and volume were counted. Then, the container was emptied, and the procedure was repeat into three times. Same procedure was repeat with the other tap with restrictor. The principle of water flow in branch with restrictor was showed in Figure 2 with information in Formula (1).

where:

$P_3$  = pressure before restrictor (Pa)

$P_2$  = pressure after restrictor (Pa)

$d$  = opening diameter restrictor (cm)

$D$  = diameter pipa (cm)

## 2.3. Data Analysis of Restrictor Performance

The pressure loss in pipe divided into: minor and major losses. Major losses was pressure loss caused by friction of fluid flow along the constant cross section pipe.

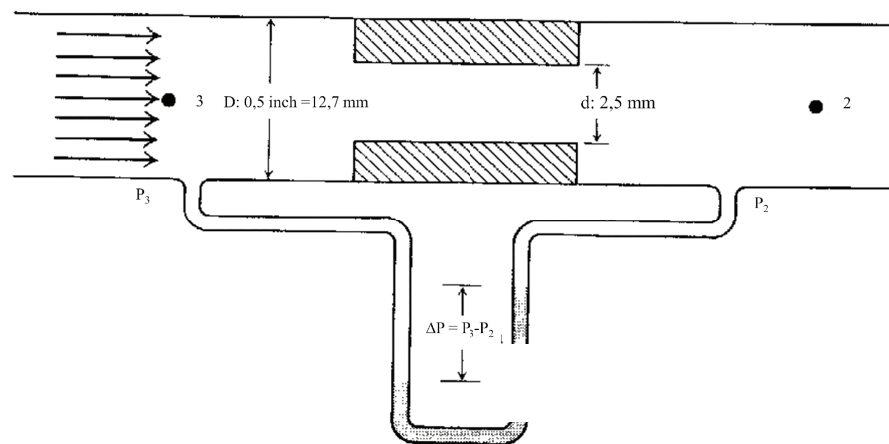

**Figure 2:** Illustration of water flow through the restrictor. Source: [3] pg.222.

While, the minor losses was losses caused by friction of the fluid with accessories, such as valve, bend, tee and pipe cross section that not constant [4]. The scheme of the piping circuit and accessories showed In Figure 3.

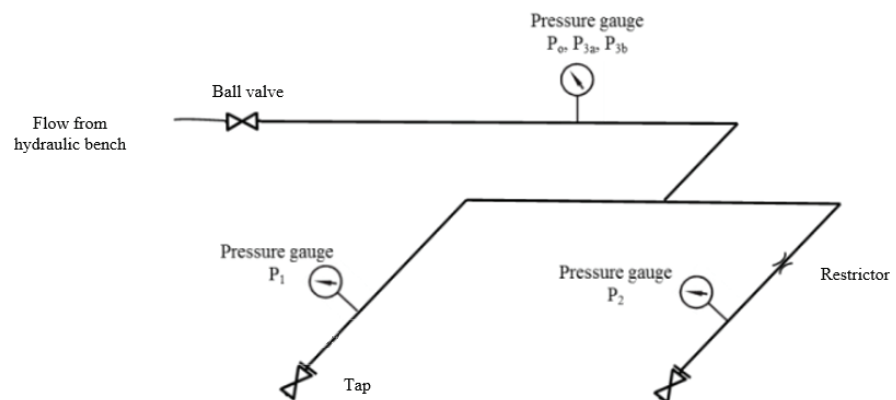

**Figure 3:** Description of measurements in the circuit.

Pressure was measured with pressure gauge that located before and after the flow was divided into two taps. Pump pressure ( $P_0$ ) was measured by opening the ball valve and shut the other tap at point 1 and 2. Final pressure after ball valve in circuit without restrictor ( $P_{3a}$ ) was obtained by opening the tap at point one and shut the tap at point two. The measurement at  $P_1$  was to determine the effect of losses of accessories, bend (minor head loss) and friction (major (head loss) along the pipe.

The loss in circuit without restrictor was difference of  $P_{3a}-P_1$ . As well in circuit with restrictor, final pressure after the ball valve with restrictor ( $P_{3b}$ ) was obtained by opening the tap in point two and shutting tap in point 1. Measurement  $P_2$  was to determine the effect of losses caused by accessories, bend and cross section change caused by

restrictor (minor head loss) and friction (major losses) along the circuit. Pressure loss in circuit with restrictor was difference of  $P_{3b}-P_2$ .

Water volume data per time unit was analyzed as function difference of static pressure, type of tap, and opening diameter of restrictor. Restrictor coefficient was calculated by using Bernoulli equation about energy loss for sudden contraction and expansion [3].

$$\frac{(P_3 - P_2) \pi^2 d^4}{8\rho Q_2^2} = (K_{SC} + K_{SE}) [1]$$

where:

$P_3$  = pressure before restrictor (Pa)

$P_2$  = pressure after restrictor (Pa)

$\rho$  = water density (gram/cm<sup>3</sup>)

$d$  = restrictor opening diameter (cm)

$D$  = pipe diameter (cm)

$Q_2$  = water discharge of circuit (cm<sup>3</sup>/s)

$K_{SC}$  = constant of sudden contraction

$K_{SE}$  = constant of sudden expansion

The performance of the restrictor was calculated with Formula (2):

$$\%Efficiency = \frac{Q_1 - Q_2}{Q_1} \times 100\% [2]$$

where:

$Q_1$  = water discharge of circuit without restrictor (cm<sup>3</sup>/sec)

$Q_2$  = water discharge of circuit with restrictor (cm<sup>3</sup>/sec)

### 3. Result and Discussion

#### 3.1. Pressure loss of circuit without restrictor

The piping circuit was made of ½" diameter PVC pipe that branched into two pipes without and with a restrictor, each of which ending with a tap. The data collected from the experiment were the water discharge and the pressure along both pipes. The initial pressure was adjusted same as the public water distribution system, which is about 2 bar then varying it by set the opening of the valve.

The pressure loss in the circuit without the restrictor was measured by opening the tap at point 1 and closing the tap at point 2 neglected ( $P_{3a}-P_1$ ) because the value was

very small based on the results of measurements with a pressure gauge at various discharge variations. Meanwhile, the pressure loss with the restrictor was measured by opening the tap at point 2 and closing the tap at point 1. The result showed that the water pressure flowed through the restrictor ( $P_2$ ) was reduced to a range of 0.02 – 0.15 bar according to the initial pressure variation ( $P_{3b}$ ) with a range of pressure loss ( $P_{3b}-P_2$ ) in the amount of 0.85 -1.85 bar. This showed the the restrictor succeeded in lowering the water pressure. The pressure loss occurs due to the presence of a restrictor which was an accessory that causes a sudden narrowing and expansion resulting in a loss of mechanical energy in the circuit [3]. The comparison of the pressure loss of the circuit without and with the restrictor is shown in Figure 4.

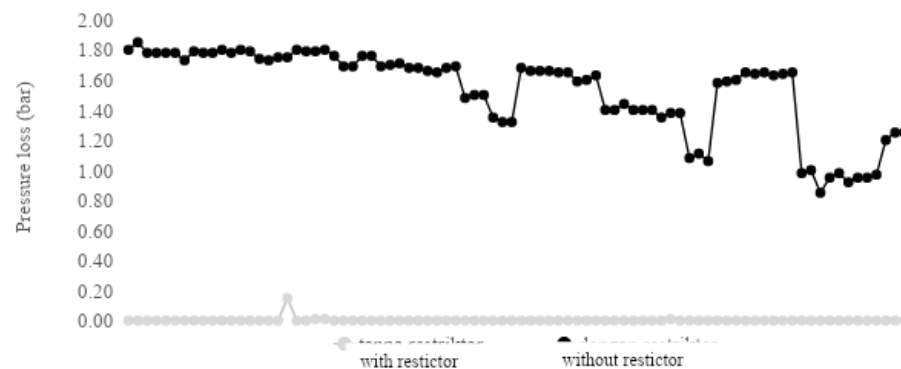

**Figure 4:** Comparison pressure loss in circuit with and without restrictor.

### 3.2. Effect of restrictor on discharge efficiency

The ratio of the discharge coming out of the valve with and without the restrictor was indicated as the discharge efficiency. The higher the efficiency means that the restrictor was able to save the discharge coming out of the valve. Based on the results of the study, it was found that there was a reduction in the flow rate that passed through the restrictor. The comparison of the discharge coming out of the circuit with and without the restrictor is shown in Figure 5.

The result showed that the efficiency was around 60-70% for large input discharges of 0.15 – 0.25 liters/second. Meanwhile, for discharges less than 0.15 liters/second (very small discharges), the efficiency dropped into 30-40%. Experiment using plug valve restrictor showed efficiency of water saving around 60% [5]. A similar study on water-saving faucets with type "solenoid valve" by students of the Department of Electrical Engineering ITS resulted in an efficiency of 37.5% [6]. But in these two studies, there is

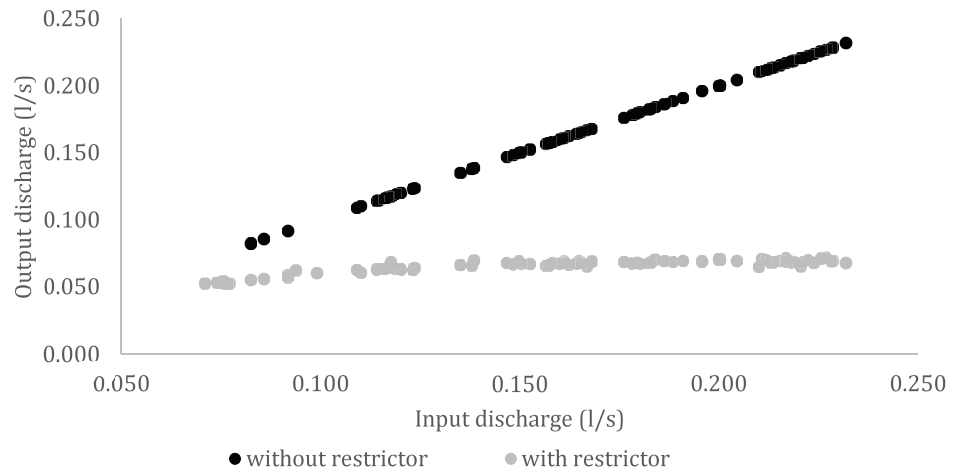

Figure 5: Comparison discharge in circuit with and without restrictor.

no further study related to the effect of discharge variations on efficiency. The efficiency of the discharge savings on the variation of the discharge can be seen in Figure 6.

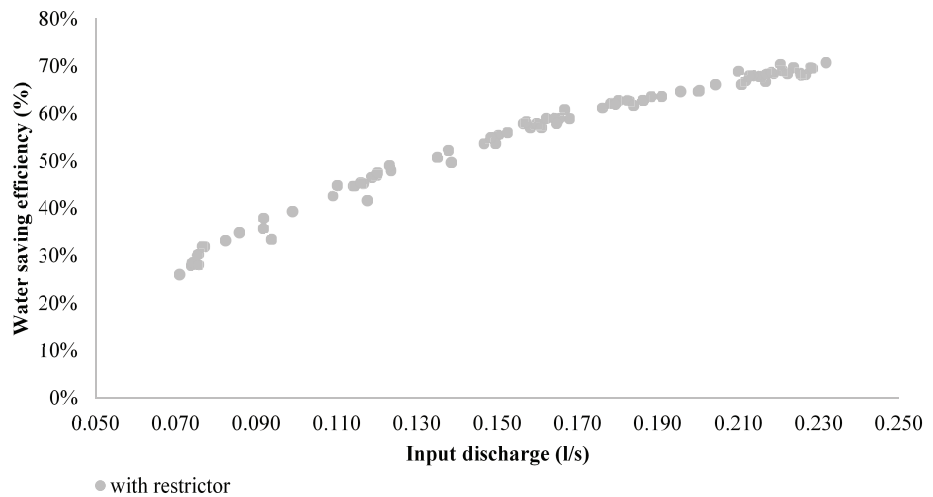

Figure 6: Input discharge vs efficiency of water discharge.

This output discharge efficiency was related to the Bernoulli Equation with the condition that there was a pressure loss due to a change in the cross-sectional area of the pipe due to the restrictor resulting in a sudden contraction and then a sudden expansion. Pressure loss occurred due to the pipe cross-sectional area ( $A$ ) suddenly becomes smaller (sudden contraction) had a head loss with a contraction coefficient which is a function of the  $A_{pipe}/A_{Expansion}$  ratio. While the flow due to sudden enlargement was similar to the outflow. The fluid left the restrictor with the smaller cross-sectional area and initially forms a jet-like structure (flow with fluid moving in layers, or laminae with one layer sliding smoothly) upon entering the larger pipe [7]. After a certain distance

of about 14 times the diameter of the restrictor (Bullen et al., 1987) downstream of the magnification, the jets become dispersed over the entire cross section of the pipe and a fully developed flow is re-established.

### 3.3. Determination of the value of the discharge constant of the effect of contraction and expansion

The determination of the K value was obtained based on the derivation of the Bernoulli Equation as stated in equation (1) by considering the energy loss due to sudden narrowing and widening ( $K_{SC}+K_{SE}$ ). From the experimental results, the experimental value was greater than the theoretical value. This indicates that there were other factors that indicate the loss of compressive height such as pipe wall and restrictor roughness, restrictor length, etc. There needs to be further research that specifically measures the contracted vein (right in the middle of the restrictor). The results of determining the K value ( $K_{SC} + K_{SE}$ ) values seen in Figure 7.

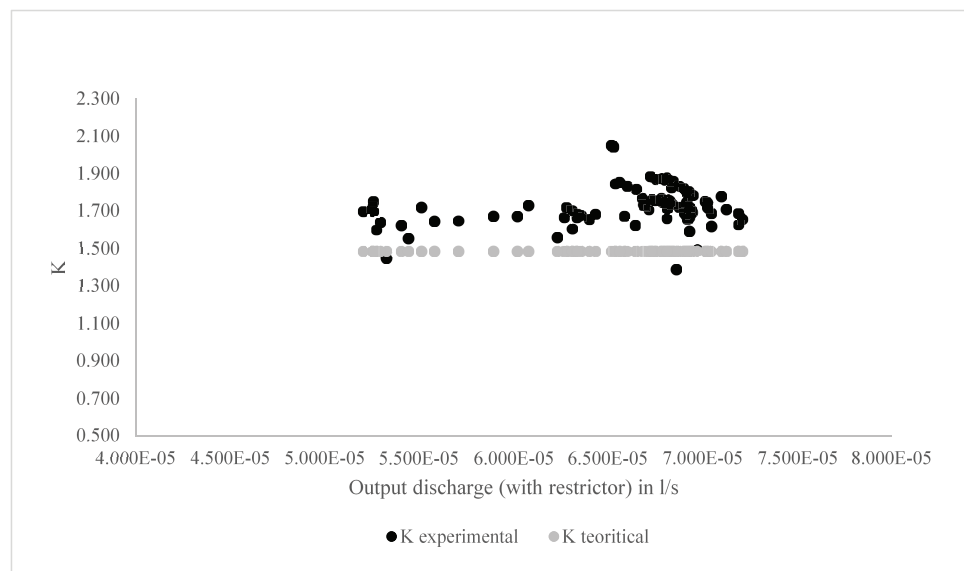

Figure 7:  $K_{theoretical}$  vs  $K_{experimental}$ .

## 4. Conclusion

The orifice restrictor played a role in reducing the output discharge at the tap. The efficiency of the restrictor in reducing the flow rate was 60-70% for input debit of 0.15 – 0.25 l/s with the output of 0.06 – 0.07 l/s with the coefficient of contraction and expansion ( $K_{SC}+K_{SE}$ ) was 1,720, higher than the theoretical 1.484. The level of accuracy



of the pressure gauge was not sufficient in measuring small head loss along the pipe that was relatively low. Future research should use a pressure gauge with a smaller scale or mercury manometer.

## References

- [1] Chiras DD. Environmental science [Internet]. Colorado: Jones & Bartlett Learning; 2013. Water resources preserving our liquid assets and protecting aquatic system; p. 248–51.
- [2] Water Systems Council [Internet]. Washington, D.C: Water Systems Council; 2003 May 7. Wellcare® info on water conservation; 2003 [cited 2020 Sep 17]. Available from: <https://www.watersystemscouncil.org/about-wsc/wellcare-program/>
- [3] Mironer A. Engineering fluid mechanics [Internet]. Auckland: McGraw-Hill International Book Company; 1979.
- [4] Ermadi D, Darmanto D. Perancangan alat praktikum pengujian headloss aliran fluida tak termampatkan. *Jurnal Ilmiah Cendekia Eksakta*. 2017;2(2):1–8.
- [5] Madonna S. Efisiensi energi melalui penghematan penggunaan air (Studi kasus: Institusi Pendidikan Tinggi Universitas Bakrie). *Jurnal Teknik Sipil*. 2016;12(4): 267–274.
- [6] Utomo YW. Mahasiswa ciptakan keran hemat air wudu [Internet]. Kompas.com; 2012 [cited 2021 Jul 14]. Available from: <https://internasional.kompas.com/read/2012/05/02/17424871/~Sains~Lab?page=all>
- [7] Munson, Bruce R. Young, Donald F. Okiishi TH. Mekanika fluida [Internet]. 4th ed. Penerbit Erlangga; 2003. Aliran viskos di dalam pipa; p. 53–64.