

Research Article

Monitoring System Design of a 4 kWp Off-grid Solar Power Plant

Widodo Pudji Muljanto, Abraham Lomi, Radimas Putra Muhammad Davi Labib*, Muhammad Wahyu Solihin

National Institute of Technology (ITN) Malang, Malang, Indonesia

Abstract.

A monitoring system is needed to determine the performance of an off-grid solar power plant. This paper presents a monitoring system design for an off-grid solar power plant with a capacity of 4 kWp. This off-grid solar power plant system was built on campus 2 of Institut Teknologi Nasional Malang. The purpose of a monitoring system is to collect and present information systematically about the state of the off-grid solar power plant system. This information can be accessed anywhere and anytime by users. Hardware used includes SPM91 to read energy meters digitally, PZEM-017 as a Modbus-based measuring instrument, and communication devices to send data to a database server. The monitoring system dashboard was built using Haiwell SCADA software. The result was a monitoring system that can display parameter data, data loggers, and graphs of the condition of the off-grid solar power plant. The PZEM-017 has an accuracy rate of 99.48% for voltage readings and 98.76% for current readings. Meanwhile, the SPM91 has an accuracy rate of 99.89% for voltage readings and 99.25% for current readings.

Corresponding Author: Radimas
Putra Muhammad Davi Labib;
email: radimas@lecturer.itn.ac.id

Published: 22 March 2024

Publishing services provided by
Knowledge E

© Widodo Pudji Muljanto et al. This article is distributed under the terms of the [Creative Commons Attribution License](#), which permits unrestricted use and redistribution provided that the original author and source are credited.

Selection and Peer-review under the responsibility of the ICEMSIT Conference Committee.

Keywords: monitoring system, off-grid solar power plant, SCADA software

1. Introduction

Electrical energy is a necessity that must exist in this era. In this case, people can get electricity apart from PLN, namely from renewable energy. Indonesia is a country that has a variety of renewable energy resources. The solar power generation system introduced in the 1950s has no pollution, noise, fuel, and easy maintenance characteristics compared to other conventional generation systems. However, despite these inherent advantages, there are some limitations in the utilization of PV systems due to the high capital costs of systems including solar cells and power conditioning systems [1].

The energy generated by the solar cell is very dependent on the conditions of sunlight. However, nowadays monitoring still uses the manual method, namely by checking directly where the generator is located. Of course, it is less effective and efficient if you want to do monitoring on a regular basis. Because environmental conditions are always changing, it will be difficult to know the performance of a Solar Power Plant installed at a

OPEN ACCESS

certain location without knowing the changing conditions of the generator parameters at that location [2]. To get the performance results from solar panels a measurement is needed on the output power of the solar panels, this measurement can be used using a multimeter, but measurements using this method still have many drawbacks, namely measurements that cannot be carried out continuously. That is why we need a system to record output data from solar panels automatically to get effective measurement data results [3].

In this study, designing hardware and software for monitoring with the Haiwell SCADA software system and data collection methods on a per-second scale. This system configuration is easily customized to collect electrical information such as voltage, current, power, and energy (kWh) of the system it is designed to monitor. This aims to make it easier for researchers to monitor a 4 kWp Off-Grid Solar Plant at Campus-II ITN Malang in real-time and online.

2. Literature Review

A solar power plant is a power plant that converts solar energy into electrical energy. Electricity generation can be done in two ways, namely directly using photovoltaic and indirectly by concentrating solar energy. Photovoltaics converts light energy directly into electricity using the photoelectric effect. The concentration of solar energy uses a system of lenses or mirrors combined with a tracking system to focus solar energy at a single point to drive a heat engine.

Solar cells or photovoltaic cells are devices that convert light energy into electrical energy using the photoelectric effect. Created for the first time in 1880 by Charles Fritts. A photovoltaic type solar power plant is a power plant that uses a voltage difference due to the photoelectric effect to generate electricity. Solar panels consist of 3 layers, the P panel layer at the top, the boundary layer in the middle, and the N panel layer at the bottom. The photoelectric effect is where sunlight causes electrons in the P panel layer to be released, so this causes protons to flow to the N panel layer at the bottom and this proton current transfer is an electric current [4].

Solar panels are solar cells arranged and connected (Fig. 1). A solar cell will normally only produce half a volt, so connecting multiple solar cells in series in a panel will produce a much more useful voltage. Most solar panels are rated for 12 volts, although higher voltage solar panels are also available [5]. Solar panels can be connected to make a solar array. Connecting multiple panels can result in a greater current or voltage. These types of solar cells are classified based on manufacturing technology. Broadly speaking,

solar cells are divided into three types, namely Monocrystalline, Polycrystalline, and Thin Film Solar Cells (TFSC).

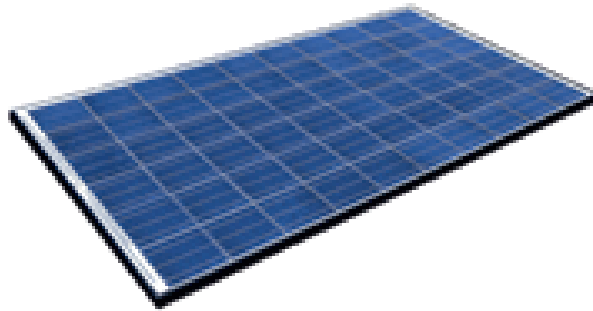

Figure 1: The solar panel.

To be used for the electricity distribution system, a solar power generation system requires a device called an inverter. It functions to convert the direct current (DC) generated by the solar panels into alternating current (AC) [6]. DC voltage from solar panels tends not to be constant according to the level of solar radiation. This non-constant DC input voltage will be converted by the inverter into a constant AC voltage that is ready to be used or connected to an existing system. Inverters are available in various power capabilities and various features such as data loggers that can provide readings from sensors. The appearance of the solar inverter is shown in Fig. 2.

Batteries will also be needed if the solar power plant is built in the form of an off-grid system. The main function of the battery is to store electricity for use at night because at that time the solar panels cannot generate electricity. In addition, the battery is also used as a support if the intensity of solar radiation is insufficient due to weather. There are two types of batteries commonly used in solar power generation systems, namely Valve Regulated Lead Acid (VRLA) batteries and Li-ion batteries. The appearance of the VRLA battery is shown in Fig. 3.

PV system control and monitoring are important because of the impact on power flow. The core part of a grid-tied PV system is the DC/AC inverter. Specifically, the task can be performed by Supervisory Control and Data Acquisition (SCADA) system. Many studies have been carried out on controlling inverters to meet the needs of the grid [7]. SCADA system has strategic significance because of the potentially serious consequences of an error or malfunction [8]. This system can connect with various hardware via the Modbus protocol.

The Modbus protocol was developed by Modicon in 1979 [9]. Modbus is the fundamental communication protocol mostly implemented in industry. It is a universal, open,



Figure 2: The solar inverter.



Figure 3: The VRLA battery.

and easy-to-use protocol. New industrial products such as PLCs, PACs, I/O devices, and instruments may have Ethernet, serial, or perhaps even wireless interfaces. The main advantage of the Modbus protocol is that it runs on all types of communication media including twisted pair cable, wireless, fiber optic, ethernet, etc. Modbus devices have memory, where factory data is stored. This memory is divided into four parts discrete input, discrete coil, input register, and holding register [10]. The discrete input and coil are 1-bit while the input register and hold register are 16-bit. Commonly used communication protocols are Modbus RTU, Modbus ASCII, and Modbus TCP.

The Modbus TCP protocol is commonly used in SCADA systems for communication between the human-machine interface and programmable logic controllers. Modbus TCP has become the industry standard communication protocol and is widely used for building sensor-cloud platforms on the Internet. However, many existing data acquisition systems built on traditional single-chip microcontrollers without sufficient resources cannot support them, because the full Modbus TCP protocol always works depending on the full operating system occupying abundant hardware resources. Therefore, the compact Modbus TCP protocol is proposed in this work to make it run efficiently and stably even on hardware platforms with limited resources.

The Modbus TCP message cycle consists of four steps shown in Fig 4. In the first step, the client sends a query (connection request) to the server, in the second step this query is acknowledged or accepted by the server, in the third step the server sends a response for the function code, and in the fourth step the client gives a confirmation signal to the server which can be interrupted TCP connection.

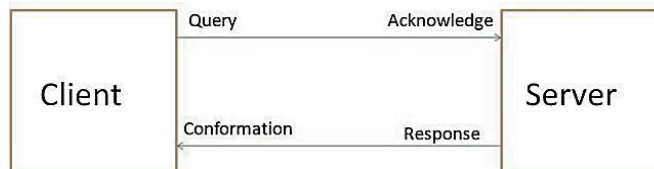

Figure 4: Modbus TCP overview.

3. Methods

3.1. Hardware configuration

In this study, SPM91 and PZEM-017 were used as monitoring devices to determine the AC output on a 4 KWp PLTS. Parameter data that can be displayed include voltage, current, power, and total energy consumption (kWh). The data collection method was carried out by designing electronic systems, installing devices, testing data readings, preparing servers, testing connectivity, integrating hardware into Haiwell SCADA and Enfill-EW11A, measuring, and analyzing. Research data is communicated using the Modbus RS485 protocol, data is collected, and then connected to the Enfill-EW11A device to change data retrieval from RS-485 to WiFi. The data obtained is processed using programming and displayed on the Haiwell SCADA dashboard, so that the reading data can be monitored in real-time and online. The hardware configuration is shown in Fig. 5.

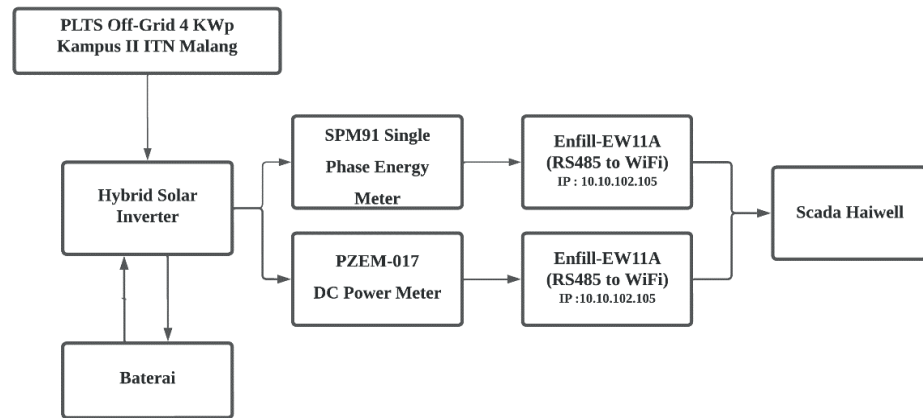

Figure 5: Block diagram of hardware configuration.

3.2. Software designs

The 4kWp off-grid solar power plant monitoring system was built using software officially provided by Haiwell. First, it is necessary to design the device configuration, as well as the names and addresses of the required parameters. Other tasks of device configuration are alarms, trends, and reports. The management alarm functions to notify the operator when some parameter exceeds the desired limit. Trend displays every change in the value of a parameter over a certain period in a chart. Meanwhile, the reporting module provides log data reports for screen displays. The monitoring software design is shown in Fig. 6.

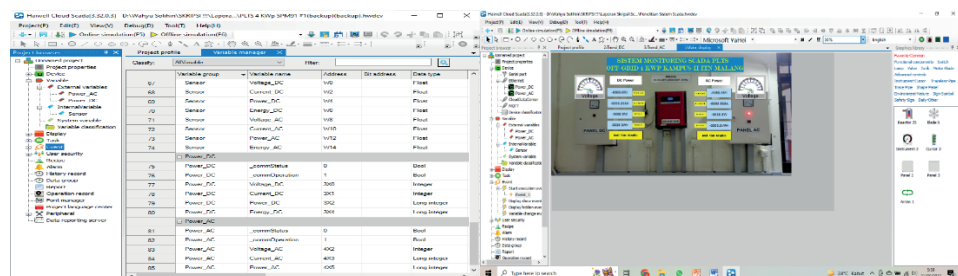

Figure 6: The software designs: (a) is device configuration, (b) is the dashboard.

After the device configuration has been carried out, then a task script can be made which aims to calibrate the output results following the measurement results from the measuring instrument. the SCADA dashboard display design of the off-grid solar power plant monitoring system also needs to be done to display the parameter output results from the measuring instrument and parameter changes each cycle during runtime.

4. Experimental Results

Validation of sensor readings used is very necessary to determine the level of reliability of the sensor. In this monitoring system, each sensor is used to monitor the electrical parameters on each channel. The main parameters that are read are voltage and amperage. Standard gauges are used as a comparison of sensor readings. The voltmeter is used to read the voltage parameter and the ammeter is used to read the electric current parameter. The validation of the PZEM-017 sensor readings is shown in table 1, while the validation of the SPM91 sensor readings is shown in table 2.

TABLE 1: PZEM-017 validation results.

Voltage Validation			Current Validation		
PZEM (V)	Voltmeter (V)	Accuracy (%)	PZEM (A)	Amperemeter (A)	Accuracy (%)
180.65	181.22	99.68	0.862	0.869	99.19
157.21	158.16	99.39	0.485	0.491	98.76
133.58	134.43	99.36	0.241	0.245	98.34
Average		99.48			98.76

TABLE 2: SPM91 validation results.

Voltage Validation			Current Validation		
SPM91 (V)	Voltmeter (V)	Accuracy (%)	SPM91 (A)	Amperemeter (A)	Accuracy (%)
232.13	232.56	99.81	0.521	0.525	99.23
230.47	230.61	99.94	0.735	0.738	99.59
228.91	229.12	99.91	0.283	0.286	98.94
Average		99.89			99.25

In general, the process of monitoring off-grid solar power generation systems using SCADA was found to be carried out. The dashboard display of the monitoring system that has been made can be seen in Fig. 7. In the experiments that have been carried out, a problem occurs in the communication system between PZEM-017 and SCADA at the start of the system the next day. This is because PZEM-017 does not get a power supply at night. After all, solar panels cannot generate electricity. PZEM-017 does not have an automatic start-up system, so the following monitoring operation requires restarting the device.

On the other hand, the SPM91 AC panel successfully transmits data, is received, and is displayed on the SCADA dashboard, which shows accurate measurement results and has an average lag time of about two to three seconds and the system has been

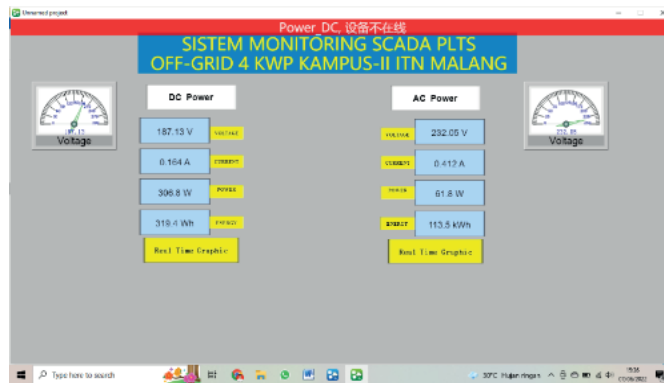
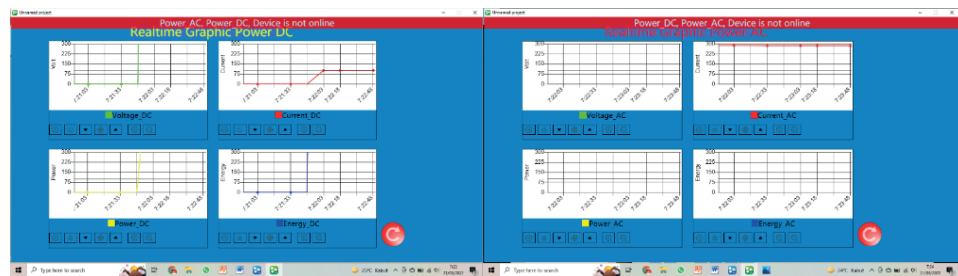

Figure 7: Dashboard view.

programmed. DC and AC parameters can also be monitored and displayed in graphical form which can change every second (Fig. 8).



(a)

(b)

Figure 8: Graphs: (a) DC parameters, (b) AC parameters.

5. Conclusion

A 4 kWp off-grid solar power plant monitoring system has been created to display some information related to the electricity generation process. The data retrieval process displayed on the SCADA dashboard has an average delay time of around 2-3 seconds because it depends on internet speed. The hardware used in this monitoring system must be integrated into Haiwell SCADA through the configuration process. The PZEM-017 used has an accuracy rate of 99.48% for voltage readings and 98.76% for current readings. While the SPM91 used has an accuracy rate of 99.89% for voltage readings and 99.25% for current readings.

Acknowledgements

We would like to thank KEMENDIKBUDRISTEKDIKTI for the funding of our research, as well as PT. Delta Jaya Engineering and Institut Teknologi Nasional Malang for in-kind support.

References

- [1] Jamaaluddin J. Utilization of Solar Power Plant as an Alternative Energy Sources Solar Applications in Building System. *J. Sci. Appl. Eng.* 2018;1(2):83–7.
- [2] Triki-Lahiani A, Bennani-Ben Abdelghani A, Slama-Belkhodja I. Fault detection and monitoring systems for photovoltaic installations: A review. *Renew Sustain Energy Rev.* 2018 Feb;82:2680–92.
- [3] Olorunfemi BO, Ogbolumani OA, Nwulu N. Solar Panels Dirt Monitoring and Cleaning for Performance Improvement: A Systematic Review on Smart Systems. *Sustainability (Basel)*. 2022;14(17):10920.
- [4] Rasal V, Raulkar V, Reddy S, Sanap J, Sarap A, Mhetre M. IoT-Based Smart Solar Monitoring System. In: Nagar AK, Jat DS, Marín-Raventós G, Mishra DK, editors. *Intelligent Sustainable Systems. Lecture Notes in Networks and Systems. Volume 334*. Singapore: Springer; 2022. https://doi.org/10.1007/978-981-16-6369-7_64.
- [5] Pescetelli S, Agresti A, Viskadourous G, Razza S, Rogdakis K, Kalogerakis I, et al. Integration of two-dimensional materials-based perovskite solar panels into a stand-alone solar farm. *Nat Energy*. 2022;7(7):597–607.
- [6] Gu Y, Green TC. “Power System Stability With a High Penetration of Inverter-Based Resources,” in *Proceedings of the IEEE*, 2022, <https://doi.org/10.1109/JPROC.2022.3179826>.
- [7] Yuanliang LI, Jun YA. Cybersecurity of smart inverters in the smart grid: A survey. *IEEE Trans Power Electron.* 2022.
- [8] Abdulsalam AB, Alsaadi HA, Hamodat Z. Control and Management of Solar PV Grid Using Scada System. In: *2022 International Congress on Human-Computer Interaction, Optimization and Robotic Applications (HORA)*. IEEE, 2022. p. 1-5.
- [9] Martins, Tiago; Oliveira, Sergio Vidal Garcia. Enhanced Modbus/Tcp Security Protocol: Authentication and Authorization Functions Supported. *Sensors* 2022; 22(20): 8024.
- [10] Katulić F, et al. Enhancing Modbus/TCP-Based Industrial Automation and Control Systems Cybersecurity Using a Misuse-Based Intrusion Detection System. In: *2022*

International Symposium on Power Electronics, Electrical Drives, Automation and Motion (SPEEDAM). IEEE, 2022. p. 964-969.