

## Conference Paper

# Development of High-Efficient, Resource-Saving Technical Solutions for Wastewater Treatment in Galvanochemical Sector

A. V. Kolesnikov, T. V. Davydkova, and V. A. Kolesnikov

Mendeleev University of Chemical Technology of Russia, Moscow, Russia

### Abstract

This article presents the results of the analysis of samples of a machine-shop for the content of organic components and heavy metal ions. The proposed modernized technological scheme uses modern technological solutions for a machine-shop. Based on the analysis of sites and sewage treatment plants of galvanic production, as well as analysis of the presence of polluting components, technical solutions, which are going to increase the intensification and efficiency of water treatment and wastewater treatment through the use of modern physical and chemical methods, technological methods and wastewater treatment devices have been developed. The introduction of additional sorption modules with activated carbon will reduce the ingress of toxic organic components (DBP, aniline, solvents: acetone, gasoline, ethyl acetate, polymer epoxy compounds, including: epoxy adhesives, polymer filler, epoxy-phenolic, phenolic-rubber and rubber adhesives, release adhesives) into wastewater. A modernized scheme using modern solutions will comply with Mosvodokanal standards.

**Keywords:** wastewater, water treatment, toxic organic components, heavy metal ions

Corresponding Author:

T. V. Davydkova

tdavydkova@muctr.ru

Published: 31 December 2020

Publishing services provided by  
**Knowledge E**

© A. V. Kolesnikov et al. This article is distributed under the terms of the [Creative Commons Attribution License](#), which permits unrestricted use and redistribution provided that the original author and source are credited.

Selection and Peer-review under the responsibility of the TECHNOGEN-2019 Conference Committee.

The industrial enterprises of the galvanochemical sector, including enterprises with dimensional and electrochemical processing sectors, production of printed circuit boards and electrical equipment, generate technological liquid wastes that exceed allowable discharge standards and contain a large number of toxic compounds, oil products, surfactants, organic compounds resulting from the etching of castings and heat-treated products, the removal of cladding layers, the application of electrocoatings, surface preparation before paintwork, and others associated with the characteristics of the products and technologies used at the enterprise [1].

The use of modern technological processes can reduce the accumulation of industrial waste, but at the same time it does not reduce the need for the development of methods for their processing. On the other hand, the use of the same technological solutions for multicomponent effluents and different impurities, their mutual influence on each other,

 **OPEN ACCESS**

significantly complicates the use of reagent, membrane and other classical methods of purification [2].

Laboratory studies have been carried out to improve the means and methods of contaminated solutions treatment. Scientific and technological approaches have been developed aimed at increasing the efficiency of the rinse waters and wastewaters conditioning and purification using the example of a machine-shop (Moscow), as well as disposal solutions, from organic pollution for complex and multicomponent systems.

The following sections are located on the territory of a machine-shop: galvanic production (GP) and the production of flexible printed circuit boards (PCB) for electronic equipment with sewage treatment plants (STP); paint and varnish production (PVP); production of composite materials (PCM); model site (MS).

At the PCB site, NaOH, Na<sub>2</sub>CO<sub>3</sub> solutions, a photoresist, a SPF-VSC photoresist removal solution, which include an unsaturated oligomer, polyester, acrylic oligomer, styrene copolymers, photosensitizers, dye, solvents are used. In large quantities these reagents fall into process medium and wastewater. The concentration of photoresist in solutions is 10-15 g/dm<sup>3</sup> (COD 10.000-12.000), and in washing water - 500-1000 COD units. Rinsing liquid containing ethyl carbitol, diacetone alcohol, butanol, dimethylformamide, triethanolamine, triethylamine, dodecyl alcohol get into wastewater during operation. The concentration of these components in water can reach 1-100 mg/dm<sup>3</sup>, COD = 100-1000 units. These solvents can easily dissolve dibutyl phthalate (DBP).

At the PCM site, epoxy resins, polymer epoxy compounds, epoxy-phenolic, phenolic-rubber and rubber adhesives, release adhesives are used. When working with binders and adhesives, the following substances may be released: epichlorohydrin, phenol, formaldehyde, solvent vapors.

Materials are included in the designed construction, and the waste generated, during the production of models, and the waste generated, as a result of irreversible chemical reactions, is converted into solid waste that must be disposed of in accordance with the established procedure at the enterprise.

At industrial enterprises of a gallochemical sector, in the course of operation at the sites, liquid technogenic wastes are generated containing a wide range of harmful chemicals of both organic (DBP, aniline, solvents, alcohols) and inorganic (Cu, Ni, Zn, Cd) nature.

In order to determine the concentrations of individual toxic components, wastewater samples from various workshops and sections of the engineering plant were taken from the wells after their sewage. The analysis of the samples (see Table 1) showed that the main organic contaminants (COD and STP) were detected in samples of PVP, PCM and MS. The largest amount of organic pollutants was found in samples of PCM. Organic

compounds are present in 2 forms, namely in solid form, as evidenced by the analysis of suspended solids and turbidity. Concentration of 1.5-5 g/dm<sup>3</sup> (samples of PVP and SPS), turbidity of 35-40 units (samples of PVP, PCM and MS). Aniline and dibutyl phthalate in all samples were not detected at the MAC control level.

Table 2 shows that the indicators of copper exceed the allowable concentrations. The high concentration of suspended solids in the sample from the sewage treatment plants of GP and PCB (0.4 g/dm<sup>3</sup>) indicates the inefficient operation of the sump. The composition of suspended solids in the sample from GP and PCB: Ca(OH)<sub>2</sub>, Mg(OH)<sub>2</sub>, Cr(OH)<sub>3</sub>, Fe(OH)<sub>3</sub>, Cu(OH)<sub>2</sub>, Ni(OH)<sub>2</sub>, Al(OH)<sub>3</sub>, carbonates and phosphates of these metals. The low content of polluting components in the sample from the total output of the SPS indicates a strong dilution of wastewater from the workshops (GP, PCB, PVP, PCM).

TABLE 1: The results of the analysis of samples of a machine-shop for the content of organic components.

Nº	Indicator	Unit	Sampling location				
			Sewage treatment plants of GP and PCB	PVP	MS	PCM	Total output of the SPS
1	COD	gO <sub>2</sub> /dm <sup>3</sup>	60	195	175	650	140
2	Total carbon	mg/dm <sup>3</sup>	203	422	748	1500	658
3	pH	unit	6,98	7,12	7,87	7,5	7,44
4	Eh (ORP)	mV	290	-20	-79	-60	-17
5	Turbidity	NTU	1,1	43,7	35,2	40	15,8
6	Suspended materials	g/dm <sup>3</sup>	0,4	1,5	1,2	5	3,5
7	Anilin	MAC	N/D				
8	DBP	MAC	N/D				

TABLE 2: The results of the analysis of samples of a machine-shop for the content of heavy metal ions.

Nº	Indicator	Unit	Sampling location				
			Sewage treatment plants of GP and PCB	PVP	MS	PCM	Sewage treatment plants of GP and PCB
1	Ni <sup>2+</sup>	mg/dm <sup>3</sup>	0,04	0,01	0,01	0,01	N/D
2	Pb <sup>2+</sup>	mg/dm <sup>3</sup>	N/D				
3	Zn <sup>2+</sup>	mg/dm <sup>3</sup>	0,14	0,08	0,05	0,05	0,04
4	Cu <sup>2+</sup>	mg/dm <sup>3</sup>	0,63	0,16	0,15	0,15	0,17
5	Cd <sup>2+</sup>	mg/dm <sup>3</sup>	N/D				
6	Al <sup>3+</sup>	mg/dm <sup>3</sup>	0,41	0,12	0,12	0,12	0,12
7	Fe <sup>3+</sup>	mg/dm <sup>3</sup>	0,04	0,09	0,06	0,06	0,08
8	Cr <sup>3+</sup>	mg/dm <sup>3</sup>	0,01	0,01	0,01	0,01	0,01

The low content of Cu, Ni, Zn, Fe, Cr, Al ions in the samples indicates a high water consumption and irregular operation of the main galvanic lines and facilities. The efficiency of sewage treatment plants of GP due to the operating life and proposed technologies is low.

The discharge of solutions, solvents, metal etching, surface preparation, degreasing leads to an increase in the concentration of organic contaminants in wastewater by 10-100 times and a decrease in the efficiency of sewage treatment plants.

It is possible to neutralize small volumes (up to 1 dm<sup>3</sup>) of organic solvents by adding to them spent activated carbon (AC) of the OU-B type in the form of solid waste. So, it is recommended to use modular local units in composites (CM) sites.

Due to the fact that pollutants are formed during the curing of coatings in the process of applying PVP, especially at elevated temperatures: formaldehyde from urea and melamine-formaldehyde coatings, phenol and formaldehyde from phenol-formaldehyde, epichlorohydrin from epoxy, dibutyl phthalate and phosphate - from polyvinyl chloride. It is necessary to strictly monitor that the concentration of harmful substances in the atmosphere of industrial premises does not exceed the MAC.

In order to reduce the concentration of wastewater pollution, it is necessary to provide their discharge from the PVP site and from the CM site to GP storage. This will reduce the concentration of organic pollutants due to sorption processes on hydroxide deposits (Fe, Al, Cr, Cu, Ni). The introduction of additional sorption modules with activated carbon will reduce the ingress of toxic organic components into wastewater.

Further (see Figure 1), the proposed scheme of sewage treatment plants for industrial enterprises of galvanotechnical sector is presented. Advantages of the proposed technical solutions:

- a modernized scheme using modern solutions will comply with Mosvodokanal standards;
- an automatic control system for cleaning parameters (pH, Eh, Red / Ox, COD) will be introduced;
- pH of the treated water will ensure removal of Cu, Ni, Zn, Cd ions;
- will allow cleaning from organic contaminants (DBP, aniline, solvents: acetone, gasoline, ethyl acetate, polymer epoxy compounds, including: epoxy adhesives, polymer filler, epoxy-phenolic, phenolic-rubber and rubber adhesives, release adhesives;
- sediment (sparingly soluble metal compounds) will be removed from the sump regularly;

- a system for the disposal of used technological solutions (pickling, degreasing, Cu, Ni) will be adopted;
- wastewater from PVP, PCM workshops, the main sources of DBP and aniline pollution will also be brought to the STP for their treatment.

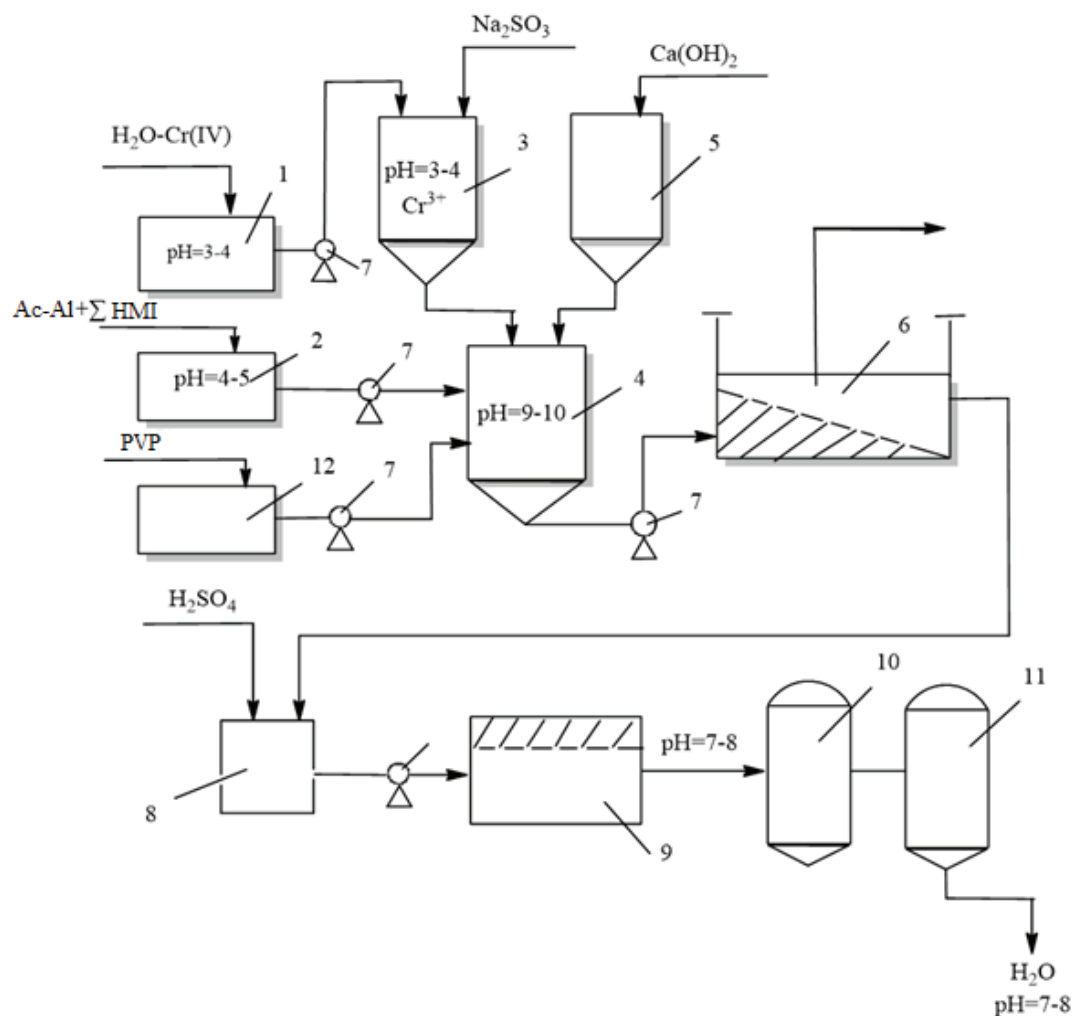

**Figure 1:** The proposed modernized technological scheme using modern technological solutions for a machine-shop: 1 - capacity-receiver of chrome-containing effluents; 2 - capacity-receiver of acid-alkaline effluents; 3 - reactor for chromium reduction; 4 - neutralization reactor; 5 - capacity for storage (dosing) of  $\text{Ca}(\text{OH})_2$ ; 6 - sump with access to the filter press; 7 - pumps; 8 - pH lowering reactor; 9-electroflotator; 10a, 10b - filters on the AU; 11 - reactor for receiving wastewater from the PVP.

Based on the analysis of sites and sewage treatment plants of galvanic production, as well as analysis of the presence of polluting components, technical solutions, which are going to increase the intensification and efficiency of water treatment and water treatment through the use of modern physical and chemical methods, technological methods and wastewater treatment devices have been developed.

*This study was financially supported by the Ministry of Education and Science of the Russian Federation under the Agreement on adjudging grant N°14.574.21.0169 September 26, 2017. Agreement ID RFMEFI57417X0169.*

## References

- [1] Decree of the Government of the Russian Federation of June 21, 2013 N 525 "On approval of the right to control the composition and properties of wastewater."
- [2] Kolesnikov, V. A., *et al.* (2017). Electroflotation in the Processes of Water Purification and Extraction of Valuable Components from Technogenic Liquid Wastes. Overview. Part 1. *Theoretical Foundations of Chemical Engineering*, vol. 51, issue 4, pp. 361–375.