

## Conference Paper

# Non-standard Heating System of Chamber Heat-treatment Furnace with Fixed Hearth

Mikhail Kazyayev<sup>1</sup>, Evgeny Kiselev<sup>1</sup>, Danila Spitchenko<sup>1</sup>, and Aleksandr Vokhmyakov<sup>2</sup>

<sup>1</sup>Ural Federal University (UrFU), Ekaterinburg, Russia

<sup>2</sup>UralTermoKomplex Research and Production Company, Ekaterinburg, Russia

## Abstract

This article describes specific features of thermal operation and design of new heat-treatment furnaces constructed and operated in conditions of production restrictions. The requirements for high-quality and energy-efficient production of finished metal products are especially manifested during final heat treatment aimed at receiving the specified physical and mechanical properties of the products.

**Keywords:** heat-treatment furnace, heating for hardening, steel sheet, heating system, high-speed recuperative burner

Corresponding Author:  
Mikhail Kazyayev  
termokomplex@r66.ru

Received: 6 June 2018  
Accepted: 15 June 2018  
Published: 17 July 2018

Publishing services provided by  
Knowledge E

© Mikhail Kazyayev et al. This article is distributed under the terms of the [Creative Commons Attribution License](#), which permits unrestricted use and redistribution provided that the original author and source are credited.

Selection and Peer-review under the responsibility of the TIM'2018 Conference Committee.

## 1. Introduction

At machine-building plants heat-treatment furnaces relating to chamber heating furnaces are operated in a wide range of temperatures, mainly from 200°C to 1250°C. In this case, very complicated heating and cooling conditions are often set for the products to be heat treated, with a big number of intermediate holdings at different temperatures, which is usually appropriate for products of the heavy engineering industry [1–3]. However, the cooling and heating conditions can also be simple, for example, for hardening of a thin steel sheet.

This article refers to the latter kind of heat-treatment conditions used at one of the plants in the Moscow Region.

Technical upgrading of old furnaces and construction of new furnaces is often faced with difficulties during designing and construction associated with a limited space available in the existing workshop filled up with different process equipment [4].

In this regard, it is necessary to develop non-standard solutions for designing the work space and heating system of the furnace but at the same time the energy efficiency and product quality requirements shall remain inviolable [5, 6].

## OPEN ACCESS

## 2. Background for Development of the Furnace Design

The furnaces were designed and constructed by UralTermoKomplex Research and Production Company, Ekaterinburg together with ZiO-Podolsk, Podolsk, Moscow Region.

Development of the unit consisting of three furnaces with a non-standard heating system was initiated by a number of purely production factors:

- a limited production site;
- a specific system of furnace loading and discharge of steel sheets using a cantilever device located on the automated lift truck;
- a high speed of furnace heating, including loaded products, from the cold condition.

## 3. Developed Furnace Design

The general arrangement of the furnaces is shown in Figure 1 and the sectional drawing of one furnace is shown in Figure 2.

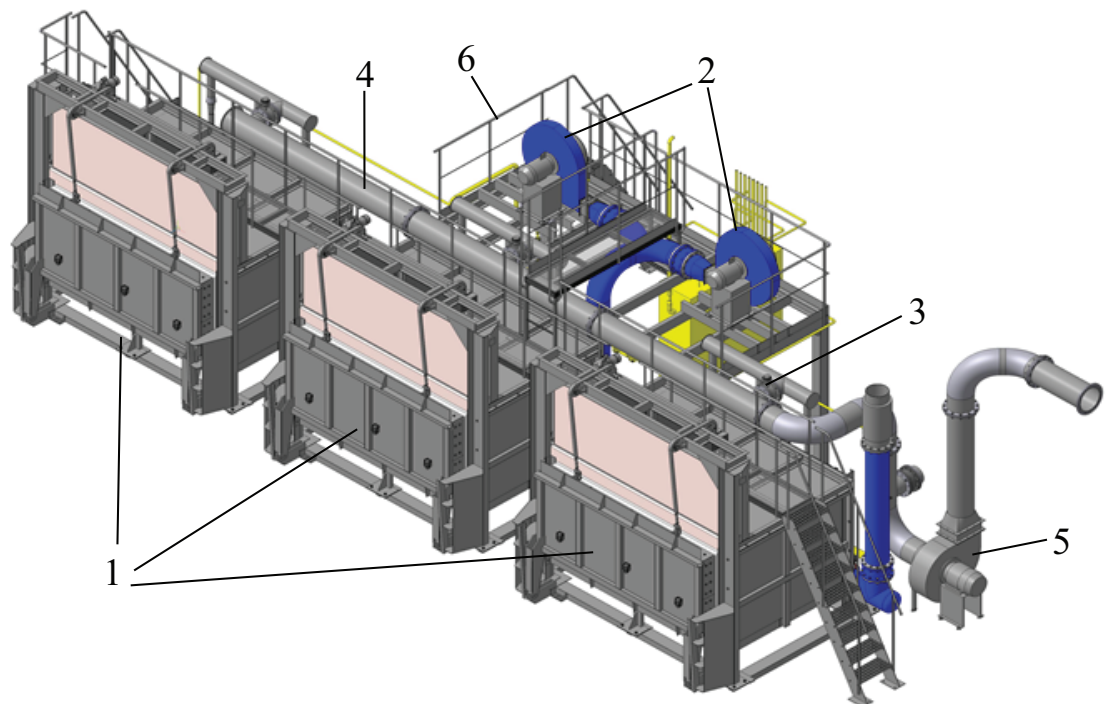

**Figure 1:** General view of the furnace unit; 1 – unit consisting of three chamber furnaces with fixed hearth; 2 – main fan and standby fan; 3 – gas distributor; 4 – furnace exhaust duct; 5 – exhaust stack; 6 – work platform.

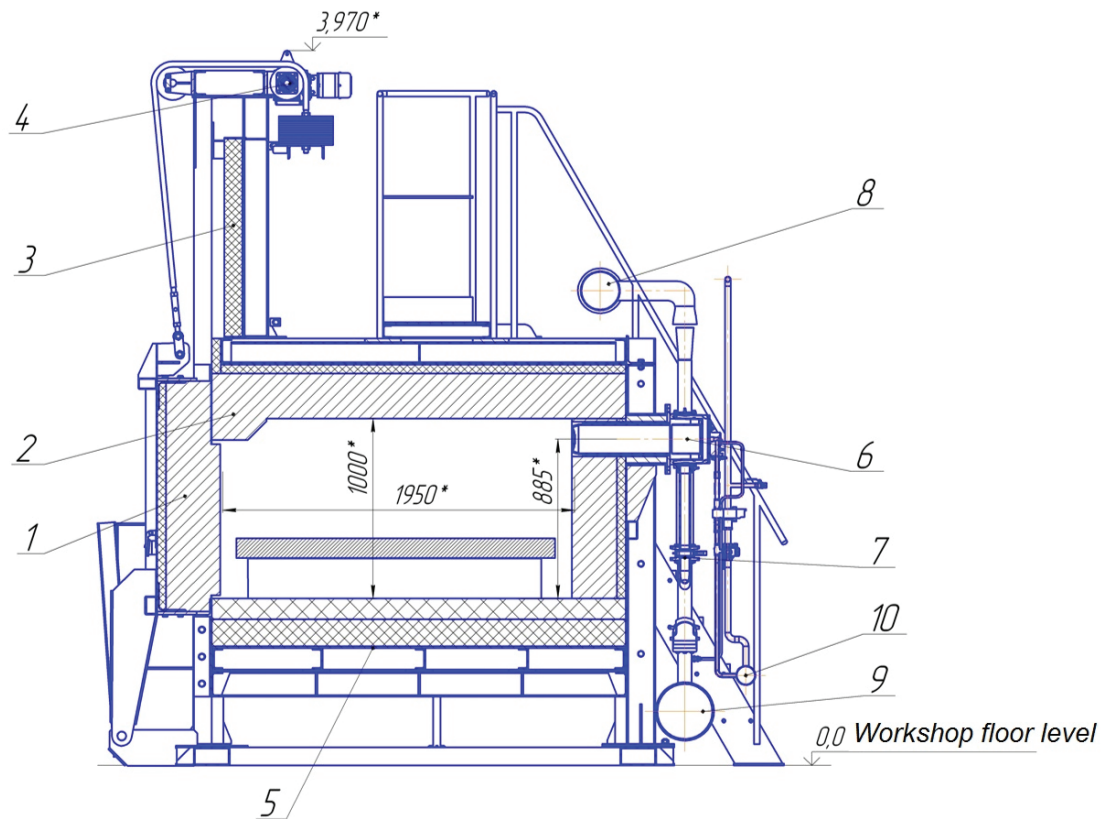

**Figure 2:** Layout of chamber furnace with fixed hearth; 1– furnace door; 2 – panel flat roof with cross beam; 3 – protecting screen; 4 – door lifting mechanism; 5 – fixed hearth with metal reinforced frame; 6 – high-speed recuperative burner; 7 – shut-off and control burner valves; 8 – exhaust duct; 9 – air duct; 10 – gas duct.

The furnace walls and flat roof are assembled from metal plate panels lined with ceramic fiber bricks.

The burners of three furnaces have a common supply of gas and air and a common discharge of combustion products.

Each burner is equipped with an individual automated process control system (APCS).

After the sheet is heated together with the furnace in accordance with the preset process conditions, it is placed in a special water-cooled press preventing the product from contraction during accelerated cooling.

The thermal conditions of the furnace are controlled by thermocouples installed in the furnace roof.

#### 4. Technical Specifications of the Furnace

The general technical specifications of the furnace are given in Table 1.

TABLE 1: Technical specifications of the chamber heat-treatment furnace with fixed hearth and end location of burners.

Parameter	Unit	Value
Work space dimensions:		
length	mm	1950
width	mm	2700
height	mm	1000
Operating conditions		periodic
Maximum weight of heated metal	kg	500
Maximum weight of load with supporting fixtures	kg	2900
Metal heating temperature (maximum)	°C	1050
Maximum heating speed of the furnace with load	°C/h	300
Fuel, calorific value	kJ/m <sup>3</sup>	natural gas, 34000
Burner type and quantity in one furnace	pcs	three recuperative high-speed Ecomax 3, ElsterKromschroder, Germany
Rated thermal capacity of the burner	kW	120
Rated gas flow rate for one burner	m <sup>3</sup> /h	12

In order to assess thermal operation of the furnace and automated control system, we carried out a comprehensive study during controlled heating of the steel sheet for hardening.

It can be seen from the technical specifications of the furnace in Table 1 that the useful mass of the heated steel is only 17% of the total mass of loaded products. Therefore, considering the requirement of the maximum heating speed from the cold condition of the furnace together with load, we carried out the study in such a way that first we heated the furnace together with load and recorded the rate of temperature elevation and then after this procedure we put portable flexible (cable) thermocouples on the surface of the heated steel at different points and recorded over time the temperature of holding and APCS operation regarding maintenance of the preset uniform heating of the sheet.

## 5. Metal Temperature Measuring

The diagram of thermocouple installation on the surface of the heated sheet is shown in Figure 2. The results of temperature measuring on the metal surface and in the furnace work space are given in Table 2.

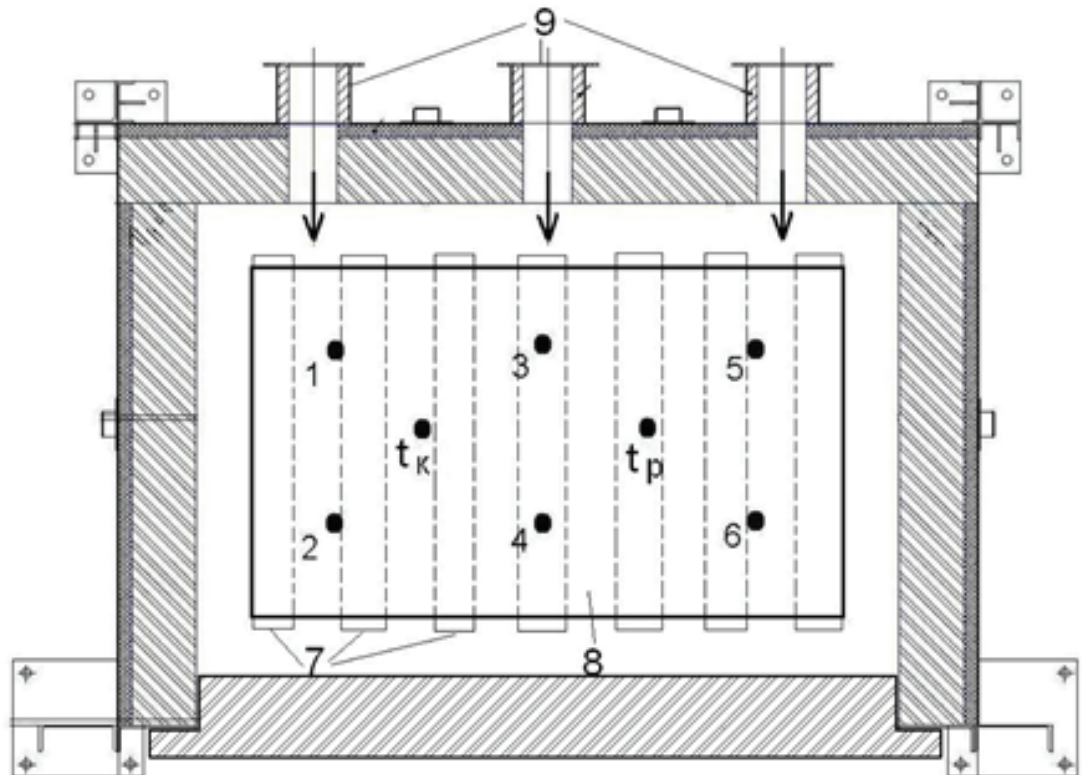

**Figure 3:** Arrangement diagram of supporting fixtures, heated sheet and thermocouple junctions in the furnace work space; 1..6 – control thermocouples installed on the sheet surface,  $t_p$  – main working stationary thermocouple,  $t_k$  – control stationary thermocouple; 7 – supporting fixtures; 8 – heated sheet; 9 – burners.

## 6. Summary

Analyzing the results of temperature measurements on the sheet surface (Table 2) within one hour of holding at the constant furnace temperature, we observed the maximum temperature fluctuations from 4 to 12°C at different points of the sheet surface within the time from  $\tau_0$  to  $\tau_{60}$  min that resulted from operation of APCS controlling operation of burners in pulsed conditions, that is, gas dynamics of the furnace work space. This operation of the automated process control system has been found quite satisfactory.

TABLE 2: Change of the sheet surface temperature and furnace work space temperature over time in the conditions of holding.

TC No.	Time, min							$\Delta t_{max}, ^\circ\text{C}$
	0	10	20	30	40	50	60	
1	960	960	969	968	965	965	964	9
2	967	961	973	961	972	970	963	12
3	960	961	962	961	962	963	964	4
4	960	960	967	961	966	962	961	7
5	962	962	963	964	964	960	961	4
6	964	962	972	967	970	967	966	10
$t_p$	967	962	967	967	968	968	965	6
$t$	973	971	973	971	973	975	973	4

Note: In these conditions of load heating the automated process control system shall maintain the furnace process temperature  $t_p = 965^\circ\text{C}$  in accordance with readings of the working thermocouple  $t_p$  (tk – control thermocouple).

In 60 minutes of holding at the constant furnace temperature, the temperature fluctuations on the surface of the heated sheet did not exceed the values indicated in the technical specification  $\Delta t_{surf} = \pm 5^\circ\text{C}$ , which confirmed the possibility of burner installation on the rear wall of the furnace.

Nevertheless, during commissioning it was established that when gases return toward burners the gas flow splits and as a result the combustion products concentrate at the top of the furnace work space and do not flow sufficiently under the heated sheet between the supporting fixtures that represent the biggest part of the load.

In future, when designing this heating system, it is necessary to model gas dynamics of the furnace in accordance with location of the loaded products and roof height over the metal surface.

## References

- [1] Kazyaev, M. D., Samoylovich, Ya. A., Kazyaev, D. M., et al. (2017). Determination of the temperature field in working rolls of the cold rolling mill at accelerated heating in the heat-treatment furnace. *News of Higher Educational Institutions – Ferrous Metallurgy*, vol. 60, no. 8, pp. 616–621.
- [2] Gusovsky, V. L., Livshitz, A. E., Usachev, A. B. (2015). *Reheating and Heat-treatment Furnaces*, p. 284. M.: Stalproekt.

- [3] Kazyav, M. D., Vokhmyakov, A. M., Kiselev, E. V., et al. (2015). Methods and results of research of complex external heat-exchange in the vertical chamber furnace for heat treatment of long products. *News of Higher Educational Institutions – Ferrous Metallurgy*, vol. 58, no. 9, pp. 667–671.
- [4] Vokhmyakov, A. M., Kazyayev, M. D., and Kiselev E. V. (2012). The chamber furnace with splitting work space, in *Proceedings of the international research and practice conference 'Theory and practice of thermal processes in metallurgy'*, pp. 176–182. Ekaterinburg: UrFU.
- [5] Druzhinin, G. M., Zaynullin, L. A., Kazyav, M. D., et al. (2014). Main tendencies of resource and energy saving in ferrous metallurgy, in *Proceedings of the International Research and Practice Conference Devoted to the 150th Anniversary of the Birth of V.E. Grum-Grzhimaylo*, pp. 205–213. Ekaterinburg: UrFU.
- [6] Kazyav, M. D., Kazyayev, D. M., and Vokhmyakov, A. M. (2015). Modern tendencies of energy saving in reheating furnaces, in *The 4th International Congress 'New Tendencies in Heat Engineering Construction'*, pp. 40–60. M.